

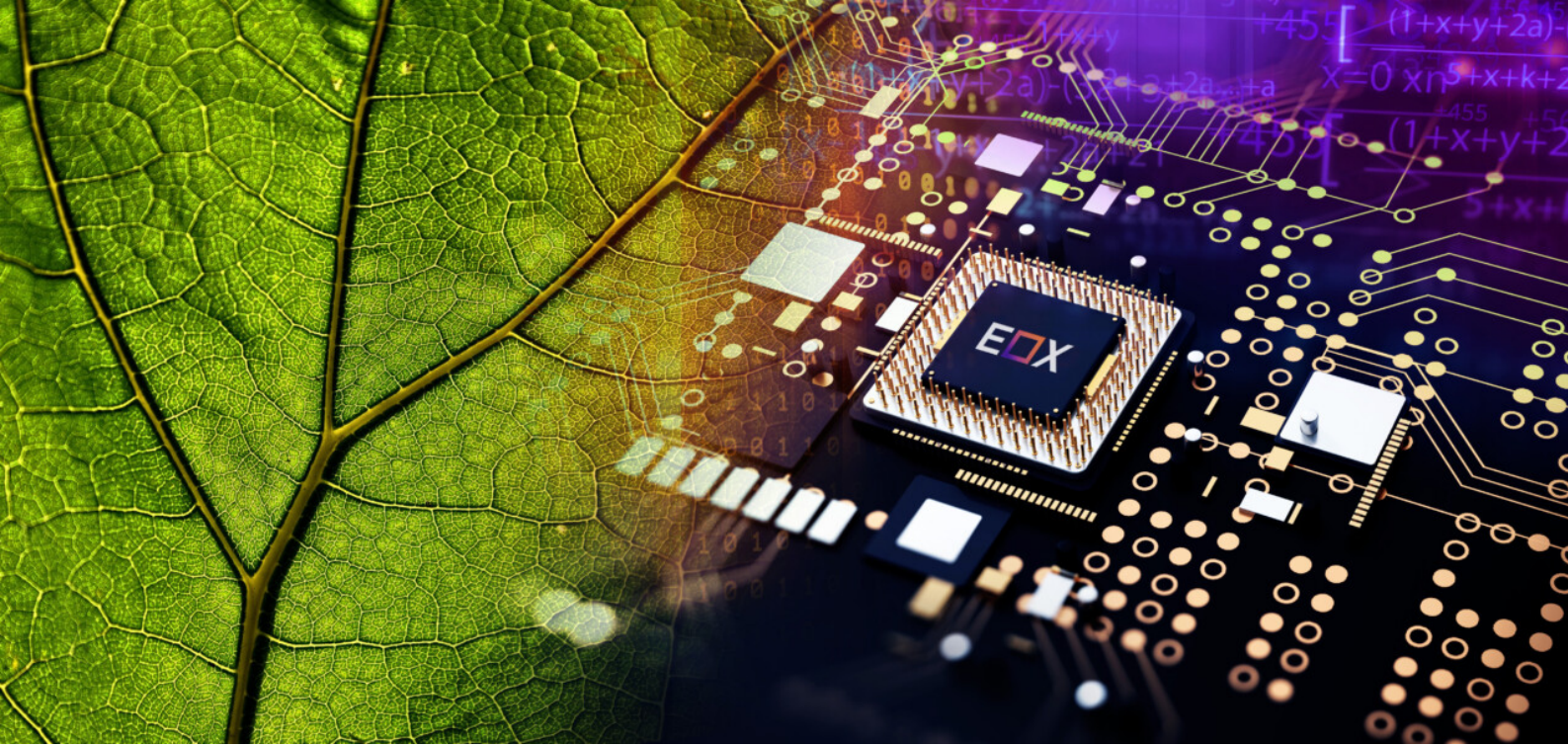

TKE

# EOX

The eco-efficient and natively digital elevator that adds value to your buildings



# THE NEW GREEN AND DIGITAL ELEVATOR

Say hello to EOX – TK Elevator’s new eco-efficient and natively digital elevator platform. EOX is a future-proof fusion of both the latest energy-saving and digital technologies in vertical mobility.

It spells out TK Elevator’s commitment to add value to your buildings: By contributing to energy efficiency **[E]** and the reduction of your carbon footprint. By putting our customers at the centre and going full circle **[O]** on today’s and tomorrow’s needs of everyone who designs, constructs, manages or uses a building. And by digitally transforming **[X]** the “everyday elevator”.

# EOX ADDS VALUE TO YOUR BUILDINGS

EOX is all you expect from an elevator – and beyond. It makes many premium specs a standard and is designed to be a natural extension of how we live and move in the world today: environmentally conscious, and always connected.

EOX is an elevator that keeps your building reliably in motion, as well as a modern digital platform that makes everything about vertical mobility more convenient and efficient.

OVERVIEW	
<b>Elevator type</b>	Machine room-less with belt technology, made in Europe
<b>Applications</b>	Residential and low-rise commercial buildings
<b>Load</b>	450 / 630 / 825 / 1000 / 1150 / 1275 / 1350 / 1600 kg
<b>Speed</b>	1.0 m/s   1.6 m/s   1.75 m/s
<b>Travel height</b>	Up to 40 m (1.0 m/s)   Up to 75 m (>1.0 m/s)
<b>Number of stops</b>	Up to 20 stops
<b>Cabin</b>	Predesigned from design lines C, B or A incl. custom cabin option
<b>Door types</b>	Side-opening with 2 panels, central-opening with 2 or 4 panels
<b>Door opening width</b>	800 – 1800 mm
<b>Door height</b>	2000 – 2400 mm
<b>Cabin height</b>	2100 – 2500 mm
<b>Energy efficiency</b>	Regenerative drive Standby-mode and eco-mode
<b>Digital components</b>	IoT-enabled and AI-ready computing hardware Smart sensors including in-cabin optical sensor
<b>Passenger experience</b>	7" / 10" in-cabin multimedia display with infotainment Elevator calls with AGILE Mobile app



# CONTENTS

2

Say hello to EOX

10

Cabin design

27

Operating panels and indicators

36

Features and options

39

Planning

49

About TK Elevator

## Discover EOX



### EOX on the web

Visit the EOX product website



### Launch event

Watch the official Virtual Product Launch event of EOX online



### Product video

Learn what EOX is all about in just two minutes of moving images

# EOX AT A GLANCE

EOX moves you in the most safe and energy-efficient ways. It's also the fulfilment of TK Elevator's promise to bring premium features to the "everyday elevator" and boost sustainability and eco-efficiency as well as digitalisation in all building categories.

EOX is our product with the broadest application scope and will fit your residential building as well as offices and hotels, public buildings like schools, healthcare facilities and hospitals.

## Making premium specs a standard



### Regenerative drive

Every EOX elevator recuperates electricity from braking and feeds it back into the building for other electricity consumers to use.



### "Swipe a ride"

Passengers can call an elevator ride on their smartphone\* as an alternative to the button-operated panels.



### Multimedia display

The standard in-cabin screen is a 7" or 10" TFT, enriching the travel experience with animation and infotainment features.



### New eco-mode

The elevator adjusts to the traffic patterns of the building and lowers its acceleration during off-peak hours.

\* The **TKE AGILE Mobile** app is available for iOS and Android at the respective app stores. User authorisation for camera access and geo-location is required for remote calls.

# A refined elevator



## Belt technology

The EOX powertrain is a state-of-the-art belt drive made in Germany. The machine features an ultra-compact design and gearless and frequency-controlled operation.



## Controller in door jamb

The ultra-compact controller is integrated into the door jamb for easy access, requiring no extra cabinet or attention during shaft construction.



## Extra-reduced shaft head & pit

EOX is optionally available with an extra-reduced shaft head to fit within standard room heights as low as 2500 mm. A reduced pit is also available.



## Reduced system weight

A 630 kg, 5-stop EOX configuration is almost 300 kg lighter than our previous comparable offerings, requiring less energy to move the cabin.



## Flexible cabin dimensions

The standard EOX cabin sizes can optionally be adjusted in 10 and 100 mm steps (load-dependent).



## Quick delivery

EOX goes from “ready to order” to “ready to ship” in as little as 20 working days.



## Safe and swift installation

EOX is installed with TK Elevator’s scaffoldless installation method.



## Code-compliant

EOX is manufactured to meet all industry standards and regulations, such as EN 81-20/50 and EN 81-70 A1.



# A sustainable and energy-efficient product



## Energy-saving features

In addition to the included VVVF regenerative drive, EOX features 100% LED lighting in the cabin and the shaft, and a Standby-mode that saves energy by automatically switching off components when the elevator is idle.

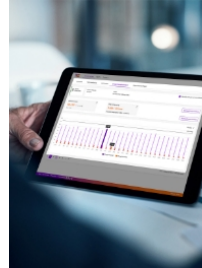

## Real-life energy consumption report

EOX owners can compile a real-life energy report via the online customer portal, showing the actual energy consumption as well as the recuperated electricity that has been fed back to the building grid via the regenerative drive.



## Sustainably made in Europe

EOX achieves Class A energy efficiency\*. TK Elevator's European manufacturing centres, where EOX elevators are produced, source 100% green electricity, decreasing the product's carbon footprint. For our packaging we use FSC®-certified materials.



## Full eco-transparency

The comprehensive documentation for the EOX product platform includes an Environmental Product Declaration (EPD) and a Health Product Declaration (HPD). For specific installations, BREEAM reports can be created.

\* Class A certified reference elevators: 630 kg, 12 m travel height and 1.000 kg, 32 m travel height in usage category 2 (125 trips per day). The energy efficiency rating of your EOX lift depends on the specific configuration, and the conditions as well as the traffic volume in your building.

View the EOX EPD®



[www.environdec.com/library/epd8258](http://www.environdec.com/library/epd8258)

# EOX is ready for tomorrow – today



## Integrated digital hardware

Native cloud connectivity and a built-in high-performance, IoT-enabled and AI-capable computing unit make EOX ready for current and future digital add-ons and services.



## Intelligent sensors

EOX includes new intelligent sensors for improved safety and reliability, such as an in-cabin optical sensor and an accelerometer, which is used to monitor the motion behaviour of the cabin and the doors.



## Customer portal

The online customer portal is the entry point to access documents, manage and view elevator performance, and subscribe to digital services. Access is free incl. a set of basic functions.



## Over-the-air software updates

EOX is able to receive software updates for digital services over the air without on-site intervention.

## Certified cybersecurity

The EOX platform has been certified to the new Cybersecurity standard IEC 62443 / ISO 8102-20, which is crucial for maintaining the safety and reliability of critical infrastructure as well as ensuring operational continuity of elevators.

The certificate means that EOX meets the latest standards for protection against unauthorised access to the lift controller and cyber-attacks.



Scan the QR code with your smart device to view the EOX Cybersecurity Certificate



# Explore EOX in 3D



Explore the interactive version of this page in the digital brochure

1. European-made drive
2. Energy recuperation
3. Smart sensors
4. New design and display
5. Controller in door jamb
6. Sustainably made at TK Elevator's European factories
7. Reliable doors
8. Slim and sturdy fixtures
9. Reduced system weight
10. Optimised installation
11. Extra-reduced shaft head
12. Reduced shaft pit



# EOX CABIN DESIGN





# Comparison overview of design lines

	Design line C	Design line B	Design line A
	available materials, options and compatibility	available materials, options and compatibility	available materials, options and compatibility
<b>Cabin wall materials</b>			
Stainless steel	✓	✓	
Skinplate (coated steel)	✓		
Melamine wood look		✓	
Colour laminate (glossy)		✓	
Wood finish laminate		✓	
Coloured safety glass			✓
<b>Mirrors</b>			
Mirror options for rear and/or side wall	3	5	5
Cabin without mirror	✓	✓	✓
<b>Ceilings</b>			
LED Plate	✓	✓	
Suspended ceilings		✓	✓
Vandal-resistant ceilings	✓	✓	✓
<b>Handrail and Skirting</b>			
Handrail types and finishes	2	2	2
Placement of handrail(s)	on 1 or 3 walls	on 1 or 3 walls	on 1 or 3 walls
Cabin without handrail	✓	✓	✓
Skirting types and finishes	1	1	1
<b>Flooring</b>			
Standard vinyl floor designs	4	4	4
<b>Customisation options</b>			
Custom flooring	✓	✓	✓
Custom ("naked") cabin for own design		✓	
<b>Cabin operating panels compatibility</b>			
Moon	✓	✓	✓
IL Variable	✓	✓	✓
Edge		✓	✓
IL Variable with black glass frontplate		✓	✓
<b>Landing operating panels and indicators compatibility</b>			
Series 30	✓	✓	✓
Series 50	✓	✓	✓
<b>Enhanced accessibility configurations</b>			
Second vertical COP (Edge or IL Variable)	✓	✓	✓
XL Horizontal COP	✓	✓	✓
XL LOP	✓	✓	✓

# C



# B

# A



# Design line C



## For functional buildings

Clean design, attractive and durable materials used throughout the cabin



## Long-lasting wall finishes

Full stainless steel or coated steel skinplate walls for maximum longevity



## Streamlined choice

Design line C combines reliability and affordability – the essences of functionality



# Design line C predesigned cabins

ST = stainless steel, SK = coated steel skinplate



## Stainless steel



C30-ST01 Stainless steel brushed

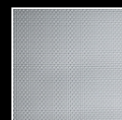

C32-ST02 Stainless steel Linen

## Skinplate



C20-SK01 White Skinplate

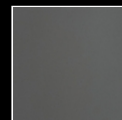

C21-SK04 Grey Skinplate



C22-SK02 Beige Skinplate

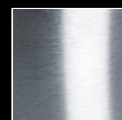

C23-SK07 Steel look Skinplate

**Predesigned Cabin C30** with ST01 stainless steel walls, white ceiling with LED Plate lighting, partial-width and partial-height safety mirror on rear wall, stainless steel handrail on side wall, anodised aluminium skirting, custom floor

## Standard ceiling for Design line C cabins

White coated structural ceiling with energy-efficient LED lighting



LED Plate ( $\leq 1000$  kg)

## Vandal-resistant ceilings available within Design line C

Unibody stainless steel suspended ceiling with integrated LED Plate. Variants with integrated trapdoor and optional ladder are available.



Steel Lightbox



Steel Grille

## Handrail and Skirting

Handrails can be positioned on one or three walls. You can also order a cabin without a handrail.



Stainless steel brushed handrail



Dark Champagne handrail



Anodised aluminium skirting

## Mirrors for Design line C cabins



Partial width / partial height<sup>1</sup>

Upper and lower full width<sup>2</sup>

Upper full width only<sup>3</sup>

Cabin without mirror

1. On rear wall, surface mounted
2. On double entrance sidewall only, surface mounted
3. On double entrance sidewall only, surface mounted (does not conform with EN 81-70)

## Flooring

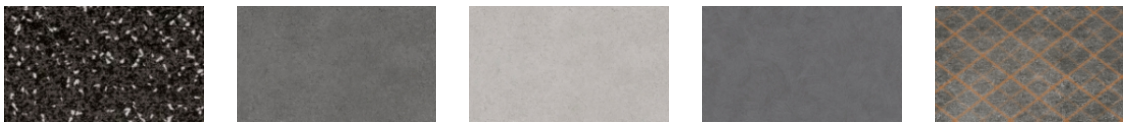

Nature Black vinyl floor

Concrete Dark Grey vinyl floor

Concrete Light Grey vinyl floor

Esquissé Grey vinyl floor

Custom floor<sup>1</sup>

1. Customer-supplied flooring with recess of  $\leq 25$  mm



# Design line B



## For the comfort segment

Visually and haptically pleasing materials, suspended ceilings for lighting effects



## Colours and wood finishes

High-quality laminates in fresh colours and natural appeal wood finishes



## Additional decoration layer

The wall decor forms a 2<sup>nd</sup> layer for better noise insulation and a flush mirror design



## More combination possibilities

Design line B offers greater flexibility to adapt the cabin to your building's architecture





# Design line B predesigned cabins









ST = stainless steel, LM-S = colour laminate (glossy), MW = melamine wood look, LW = laminate wood finish





## Stainless steel

-  B70-ST01 Stainless steel
-  B72-ST02 Stainless steel Linen



## Colour laminate

-  B50-LM01S Crystal White
-  B51-LM03S Pearl
-  B52-LM02S Folkstone
-  B53-LM08S Maui
-  B54-LM12S Levante
-  B55-LM05S Kashmir
-  B56-LM09S Amarena
-  B57-LM06S Dark Chocolate
-  B58-LM07S Diamond Black

## Melamine wood look

-  B60-MW01 Majestic Acacia
-  B61-MW02 Moon Cherry

## Laminate wood finish

-  B65-LW02 Natural Cane
-  B66-LW03 Rattan Cane
-  B67-LW07 Burnt Strand

## Customisation option

-  B90 custom "naked" cabin

**Predesigned Cabin B66** with LW03 Rattan Cane wood finish laminate walls, suspended ceiling Lightbox with LED lighting, partial-width and partial-height flush safety mirror on rear wall, stainless steel handrail on side wall, anodised aluminium skirting, custom floor

## Standard ceiling for Design line B cabins

White coated structural ceiling with energy-efficient LED lighting



LED Plate ( $\leq 1000$  kg)

## Suspended ceilings available within Design line B

Polycarbonate white ceiling with stainless steel frame and integrated LED lighting



Lightbox

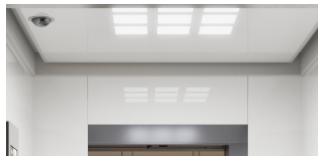

Grille

## Vandal-resistant ceilings available within Design line B

Unibody stainless steel suspended ceiling with integrated LED Plate. Variants with integrated trapdoor and optional ladder are available.



Steel Lightbox



Steel Grille

## Handrail and Skirting

Handrails can be positioned on one or three walls. You can also order a cabin without a handrail.



Stainless steel brushed handrail



Dark Champagne handrail



Anodised aluminium skirting

### Mirrors for Design line B cabins / single entrance

All mirrors are flush mounted.



Partial width / partial height



Full width / mid height<sup>1</sup>



Full width / full height<sup>2</sup>



Cabin without mirror

1. With handrails on all 3 walls only. Rear wall handrail placed on aluminium profile
2. With handrails on all 3 walls only. Rear wall handrail placed on aluminium profile

### Mirrors for Design line B cabins / double entrance

All mirrors are flush mounted with handrail placed on aluminium profile.



Upper and lower full width



Upper full width only<sup>1</sup>



Cabin without mirror

1. Does not conform with EN 81-70

## Bumpers

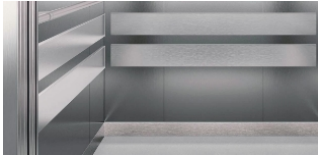

Stainless steel



Black PVC

## Flooring

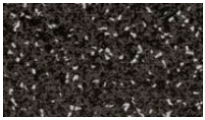

Nature Black vinyl floor



Concrete Dark Grey vinyl floor

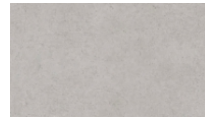

Concrete Light Grey vinyl floor

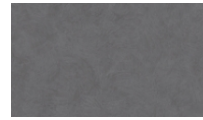

Esquissé Grey vinyl floor

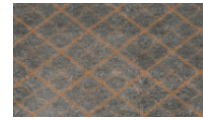

Custom floor<sup>1</sup>

1. Customer-supplied flooring with recess of  $\leq 25$  mm

## Custom cabin for your own design

If you are looking for maximum individualisation of your EOX cabin design, the “naked cabin” (B90) is for you. With this option, you order a raw cabin with galvanised steel structural walls. You can then apply and install your own custom cabin design:

- wall decor panels
- mirror
- skirting
- handrail
- flooring

Please consider that some restrictions may apply in regards to materials used, the added weight to the cabin etc. Your TK Elevator sales representative will gladly advise you on the technical requirements and assist in the realisation of your custom cabin design.

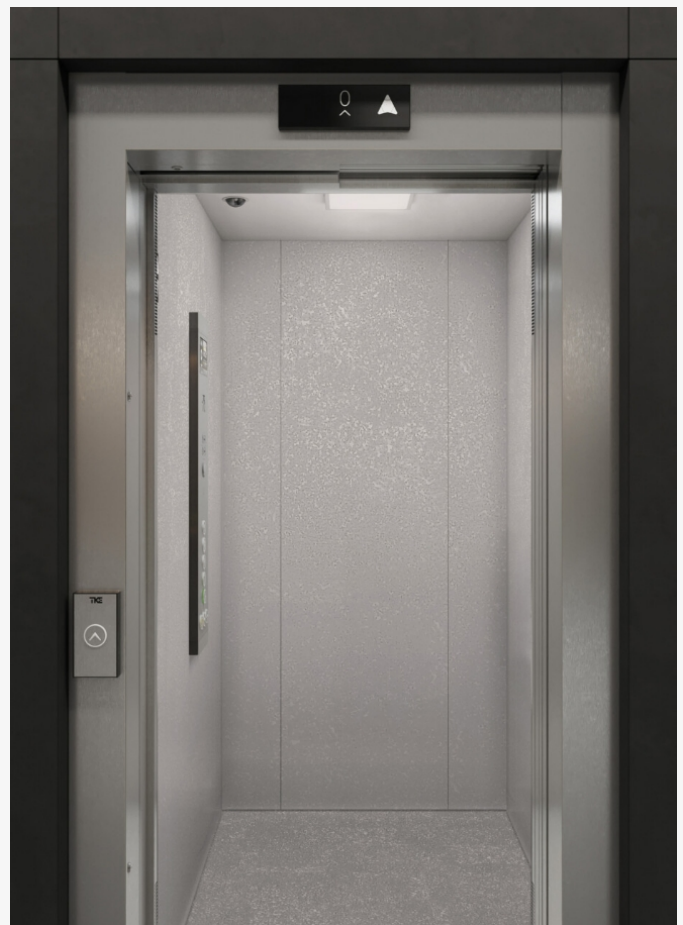

# Design line A



## For premium segment

Sophisticated elegance that blends in with any building's architecture



## Coloured safety glass walls

The glassed walls generate stunning light reflections and make the cabin appear larger



## Additional decoration layer

The wall decor forms a 2<sup>nd</sup> layer for better noise insulation and a flush mirror design



# Design line A predefined cabins

GL = coloured safety glass



## Coloured safety glass



A50-GL01 Crystal White



A51-GL03 Pearl



A52-GL02 Folkstone



A53-GL08 Maui



A54-GL11 Lemon



A55-GL10 Levante

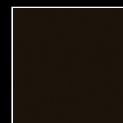

A56-GL06 Dark Chocolate

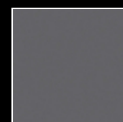

A57-GL13 Storm

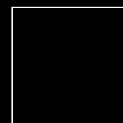

A58-GL07 Diamond Black

**Predefined Cabin A56** with GL07 Diamond Black coloured safety glass walls, suspended ceiling Lightbox with LED lighting, partial-width and partial-height flush safety mirror on rear wall, stainless steel handrail on side wall, anodised aluminium skirting, custom floor

## Suspended ceilings available within Design line A

Polycarbonate white ceiling with stainless steel frame and integrated LED lighting



Lightbox



Grille

## Vandal-resistant ceilings available within Design line A

Unibody stainless steel suspended ceiling with integrated LED Plate. Variants with integrated trapdoor and optional ladder are available.



Steel Lightbox



Steel Grille

## Handrail and Skirting

Handrails can be positioned on one or three walls. You can also order a cabin without a handrail.



Stainless steel brushed handrail



Dark Champagne handrail



Anodised aluminium skirting

## Flooring

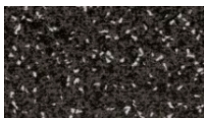

Nature Black vinyl floor

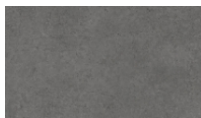

Concrete Dark Grey vinyl floor

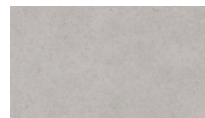

Concrete Light Grey vinyl floor

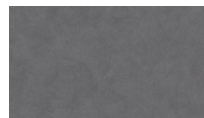

Esquissé Grey vinyl floor



Custom floor<sup>1</sup>

1. Customer-supplied flooring with recess of  $\leq 25$  mm



### Mirrors for Design line A cabins / single entrance

All mirrors are flush mounted.



Partial width / partial height



Full width / mid height<sup>1</sup>



Full width / full height<sup>2</sup>



Cabin without mirror

1. Available only with handrails on 3 walls. Rear wall handrail placed on aluminium profile
2. Available only with handrails on 3 walls. Rear wall handrail placed on aluminium profile

### Mirrors for Design line A cabins / double entrance

All mirrors are flush mounted with handrail placed on aluminium profile.



Upper and lower full width



Upper full width only<sup>1</sup>



Cabin without mirror

1. Does not conform with EN 81-70

Take a 360° look inside



A



B



C



Explore this interactive content in the digital version of this brochure

# OPERATING PANELS AND INDICATORS



# A transformed passenger experience

Previously reserved for the comfort and premium segment, EOX now establishes the in-cabin multimedia display as a standard. On top of its main job, telling passengers where the elevator is travelling, the 7-inch or 10-inch TFT screen features a news widget with the headlines of the day and the local weather forecast. The 10-inch version additionally has a “next stops” indicator informing about the upcoming travel route.

All cabin operating panels available for EOX come with this gorgeous screen that truly transforms the way passengers experience an elevator ride in your buildings.



## Configurable themes and layouts

The display can be configured with a light theme, alternative layouts or without infotainment widgets, showing just the travel information.





# Moon cabin and Edge operating panels



## Moon

The compact Moon cabin operating panel impresses with a no-nonsense design and clear functionality focus. The visual highlight is the standard-equipped 7-inch TFT multimedia display. It offers space for up to 18 push-buttons, including auxiliary buttons or key switches, on a brushed stainless steel frontplate. With tactile symbols and and/or braille lettering on the standard DB buttons, visual and acoustic passenger input acknowledgement, integrated emergency lighting, as well as a voice synthesizer for travel and floor announcements, the Moon COP fulfills the EN 81-70 accessibility requirements. A vandal-resistant variant with stainless steel VB buttons is optionally available. Dimensions are 1055×214×33 mm.

Push buttons available for Moon are DB series with stainless steel silver or black faceplate, and the stainless steel, vandal-resistant VB series.



## Edge

With its stainless steel front and an elegant black glass top, the Edge cabin operating panel is a popular choice for comfort and premium segment buildings. Its name is derived from the unique design with sloping top and bottom edges. The standard-equipped 10" multimedia screen is integrated seamlessly behind the glass cover. The Edge COP can fit up to 24 buttons incl. auxiliary buttons or key switches. For EN 81-70 accessibility, there is audiovisual input confirmation as well as a voice synthesizer for travel announcements. Optionally, an inductive loop for passengers with hearing aids is available. Edge is available for Design line A and B cabins as well as in a dual COP configuration. Dimensions are 1140×260×36 mm.

Push buttons available for Edge are DB series with stainless steel silver or black faceplate, and the stainless steel vandal-resistant VB series.



# IL Variable operating panel

## IL Variable

The IL Variable is the only cabin operating panel for EOX that sits flush with the cabin wall. Its straightforward design with a single-piece stainless steel front cover, reaching from top to bottom of the cabin, has become a timeless classic.

In the EOX elevator it is upgraded with a 10" multimedia display and accessibility features, such as audiovisual input confirmation, voice synthesizer and optional inductive loop for passengers with hearing aids. It can host up to 24 buttons incl. auxiliary buttons and key switches. Available in stainless steel brushed or linen finish. IL Variable is available for all Design lines and also in a dual COP configuration. Dimensions are cabin height x 260 mm.

Push buttons available for IL Variable are DB series with stainless steel silver or black faceplate, and the stainless steel vandal-resistant VB series.



## Newly available: IL Variable with black glass frontplate

The IL Variable cabin operating panel is now available exclusively for Design line A and B cabins with a black safety glass frontplate for an even more elegant appearance. The specifications and capabilities remain the same as with the stainless steel variant. DB series buttons in stainless steel black are recommended.



# Series 30 landing fixtures



## LOP 31

The slim LOP 31 landing operating panel measures just 65×160×21 mm and comes with a unibody stainless steel enclosure. It's surface-mounted on the landing door frame or on the wall and features TK Elevator's tried and tested DB buttons with tactile symbols and stainless steel frontplates. In addition to the white confirmation light of the buttons, there's also an acoustic acknowledgement with adjustable volume level. LOP 31 is also available with (euro) key switches or vandal-resistant VB push-buttons.



## LIDC 31

The LIDC 31 landing direction indicator is elegantly integrated into the door portal of the cabin, travelling with the elevator. It signals the current direction to passengers by illuminating its 40 mm high up and down arrows, visible inside the cabin and to passengers in the landing upon arrival of the elevator. There's also an integrated gong sound that indicates the travel direction to passengers acoustically. LIDC 31 is compatible with Series 50 operating panels.



## LID 31

LID 31 combines the stainless steel unibody enclosure of the LOP 31 panel and the illuminating arrows of LIDC 31 into a landing direction indicator, surface-mounted on the landing door frame or the wall. It informs passengers awaiting the elevator about its current travel direction.

## Push buttons

The Series 30 landing operating panel is available with TK Elevator's popular DB series buttons with stainless steel faceplate, and the stainless steel and vandal-resistant VB series buttons.





# Series 50 landing operating panels

## LOP 51

With its brushed stainless steel faceplate and black polycarbonate enclosure the LOP 51 forms the basis of TK Elevator's modular Series 50 operating fixtures. The surface-mounted landing operating panel fulfills all EN 81-70 requirements from the button luminance contrast to the acoustic input acknowledgement with adjustable volume level. Dimensions are 91x171x19 mm. Standard-equipped with round DB push-buttons, it can also be configured with (euro) key switches and vandal-resistant VB buttons.



## LOP 52

LOP 52 extends the base panel with an additional module below that can accommodate either a single (euro) key switch or a push-button that can be used for special access functions. Dimensions are 91x261x19 mm.



## LOP 53

LOP 53 extends the base panel with a display module on top. The glass-covered 3,5" TFT screen shows the position and travel direction of the elevator. Dimensions are 91x261x19 mm.



## LOP 50

LOP 50 simply does it all by combining the base panel with the keyswitch/button extension below, and the 3,5" TFT display module on top. Dimensions are 91x350x19 mm.

## Push buttons

The Series 50 landing operating panels are available with TK Elevator's popular DB series buttons with stainless steel silver or black faceplate, and the stainless steel and vandal-resistant VB series buttons.







# Series 50 landing indicators



## LIP 50

The LIP 50 landing indicator panel is surface-mounted on the door lintel or wall, informing passengers of the current floor level position and travel direction of the elevator via two illuminating arrows and a TFT display. Black glass front with polycarbonate enclosure. LIP 50 is available only for the main landing. Dimensions are 260×91×19 mm.



## LID 50/51

The LID 50 landing indicator panel shows the current travel direction of the elevator with arrow LEDs. It's surface mounted on the door frame or wall. Black glass front with polycarbonate enclosure. The variant LID 51 includes a gong signal. Dimensions are 91×101×19 mm.



## LIDC 31

Although part of the Series 30 landing fixtures, the LIDC 31 landing direction indicator is compatible with Series 50, too. It is elegantly integrated into the door portal of the cabin, travelling with the elevator and signals the current direction to passengers by illuminating its 40 mm high up and down arrows.



## Matching design with black glass front

All Series 50 landing operating panels are also available with a black glass faceplate instead of stainless steel, allowing you to create an exact visual match with the glass-covered Series 50 indicator panels.



# Enhanced accessibility configurations

EOX has been designed with accessibility in mind. It starts with the use of mechanical buttons in all our control panels, rather than touch-sensitive panels or touch screens, the ergonomic design of components such as handrails and continues with standard-included features that ensure that passengers with physical limitations or disabilities can use the elevator. In other words: Every EOX elevator fulfils the EN 81-70 norm – but you can also go way beyond these minimum requirements and enhance accessibility in your EOX elevator and your building to the highest standards.



## Second vertical COP

Adding a second vertical COP improves comfort and passenger flow with very wide or very deep cabins. EOX offers a variety of placement configurations (left/right, front/rear, centred/displaced) to ensure all passengers entering the cabin can reach their destination button. A dual COP configuration is available with Edge or IL Variable.



## XL Horizontal COP

The XL Horizontal COP is an auxiliary cabin operating panel with extra-large push buttons. It's positioned on the side wall opposite of the main COP at a height of 850 mm. Stainless steel casing with up to eight destination buttons with tactile symbols and braille lettering. Available with all cabin design lines.



## XL LOP

The XL LOP landing operating panel is the companion to the XL Horizontal COP. It's flush-mounted on the building wall and can hold one or two extra-large push buttons with tactile symbols and audiovisual confirmation signal. Dimensions are 80×252×2 mm.



### “Wheelchair button”

Technically referred to as extended door opening time, the “wheelchair button” can be combined with Series 50 landing operating panels or added in a separate casing next to the main LOP on the building wall. When pushed, the doors will stay open longer to allow for comfortable boarding.



### Inductive loop

Fitting your EOX elevator with an induction loop will enable hearing-impaired passengers to receive audio transmissions from the voice announcement and emergency call systems directly to their hearing aid. An icon on the COP indicates the feature.





# Features and options I

- Standard
- Option

## ENERGY EFFICIENCY

Regenerative drive	●
LED cabin and shaft lighting	●
Standby-mode	●
Eco-mode	●
Energy consumption report via customer portal *	●

## DIGITAL FEATURES AND SERVICES \*

Integrated digital hardware with IoT-enabled and AI-ready high-performance computing unit	●
Customer portal access with administrative information and basic IoT performance data overview	●
Notifications and alerts (self-service)	●
In-cabin infotainment with news and weather widget	●
Predefined layouts and themes for multimedia display	●
Monitoring dashboard	○
API-connectivity	○
Over-the-air updates for digital services	●

## LAYOUT

Machine room-less	●
Controller integrated in door jamb	●
External slim controller cabinet in selectable floor	○
Fixed cabin dimensions	●
Flexible car dimension 10mm-steps (≤630 kg)	○
Flexible car dimension 100mm-steps (>630 kg)	○
Extra-reduced shaft head (≤1000 kg)	○
Reduced shaft pit (≤1000 kg)	○
Trapdoor in ceiling with/without ladder	○
2,5 m guide rails	○
Safety gear on counterweight	○

## SAFETY, MAINTENANCE & REGULATIONS

In-cabin optical sensor	●
Accelerometer in door drive	●
Automatic evacuation to next landing	●
Automatic evacuation to next landing (with UPS)	○
Automatic evacuation to any landing (with UPS)	○
Evacuation via emergency power supply	○
Advanced troubleshooting for service technician*	●
Remote intervention by TKE service operator**	●
Light curtain protection	●
Emergency lighting in cabin 1 h	●
VoIP-based digital emergency call system	●
Two-way intercom	●
Three-way intercom (TKE DES)	○
Lift warden function	○
Water sensor in pit	○
Halogen-free shaft wiring (excl. motor and travelling cable)	○
<b>Codes &amp; standards</b>	
Doors fire rating E-120	●
Doors fire rating EW-60	○
Doors fire rating EI-60 ***	○
Doors fire rating EI-120 ***	○
EN 81-20/50, Lifts construction	●
EN 81-21, Lifts construction in existing buildings	○
EN 81-28, Emergency call system	●
EN 81-70 A1, Accessibility to lifts	●
EN 81-71, Vandal resistant, partially Category 1	○
EN 81-72, Firefighter lifts	○
EN 81-73, Fire evacuation (ext. signal, manual recall, dynamic evacuation up to 7 landings)	○
EN 81-77, Seismic, Category 0	●
EN 81-77, Seismic, Category 1 / 2	○

\* Provision of all digital (software) services is dependent on an active maintenance contract with TK Elevator

\*\* Please confirm the availability of this feature in your region with your TK Elevator sales representative

\*\*\* Doors fire rating EI-60 and EI-120 not available for landing doors where integrated controller is placed

The details quoted on this page can only be viewed as binding when confirmed expressly in writing.

# Features and options II

- Standard
- Option

COMFORT	DESIGN
<b>Accessibility</b>	Pre-designed cabin skinplate ●
Door open/close and alarm push button ●	Pre-designed cabin melamine, colour, wood laminate ○
Big push buttons with braille lettering (COP) ●	Pre-designed cabin stainless steel ○
Round green frame in main floor push button ●	Pre-designed cabin coloured safety glass ○
Adjustable sound level (35-65 dBA) ●	LED Plate ceiling (≤1000 kg) ●
Luminance contrast in fixtures ●	Suspended ("false") ceiling ○
Voice announcement ●	Preparation for own custom flooring ≤ 25 mm ○
Inductive loop (EN 81-70) ○	Custom cabin ○
"Wheelchair button" in LOP for extended door opening time ○	<b>Cabin operating panels</b>
<b>Access Control</b>	Moon COP with 7" multimedia display ●
Elevator calls with AGILE Mobile app (GPS, QR) * ●	Edge COP with 10" multimedia display ○
Cancellation of calls by double click in COP ●	IL Variable COP with 10" multimedia display ○
(Euro) key switch in COP for access/functions ○	<b>Series 30 landing fixtures</b>
(Euro) key switch in LOP for access/functions ○	LOP 31 landing operating panel on door frame ●
Combined key switch + push button in COP/LOP ○	LOP 31 landing operating panel on wall ○
Preference/independent service of COP ○	LIDC 31 landing arrow indicator in cabin portal ●
Encoded car calls (ECC) ○	LID 31 landing arrow indicator, door frame or wall ○
Out of service LOP ○	<b>Series 50 landing fixtures</b>
Preparation for card reader (LOP/COP) ○	LOP 50-53 landing operating panel, door frame or wall ○
VIP function ○	LIP 50 position indicator panel, door lintel or wall ○
Penthouse control ○	LID 50/51 arrow indicator, door frame or wall ○
Shabbat mode ○	<b>Others</b>
<b>Others</b>	Vandal-resistant Moon, Edge or IL Variable COP ○
Group control system with up to 4 elevators ○	Vandal-resistant LOP ○
Lift out of a group ○	Vandal-resistant suspended ceiling ○
Uneven groups in duplex (3rd call button) ○	Second COP in cabin (Edge or IL Variable only) ○
Full collective controller ○	XL Horizontal COP ○
Universal (Taxi) ○	XL LOP ○
Parking level at main landing floor ●	Shared LOP for duplex ○
Building management system (BMS) ○	<b>Landing &amp; cabin doors</b>
Car ventilation fan (auto / button / key switch) ○	Landing doors prime coated in RAL 7032 ●
Controller, cabin light shutdown in LOP key switch ○	Cabin doors in stainless steel (AISI 441) ●
Pre-opening of doors ○	Landing doors in stainless steel (AISI 441) ○
CCTV multimedia travelling cable ○	Cabin / landing doors in st. steel (AISI 316) ○
	Cabin / landing doors in st. steel linen (AISI 304) ○

\* Provision of all digital (software) services is dependent on an active maintenance contract with TK Elevator

The details quoted on this page can only be viewed as binding when confirmed expressly in writing.



# PLANNING



# Shaft layout

## Values

<b>SD / SW</b>	see dimensions pages
<b>SH</b>	CH + 1180 mm (1 m/s) min. 3615 mm (1.6 m/s) min. 3735 mm (1.75 m/s)
<b>SH red.</b>	CH + 400 mm (1 m/s)
<b>SP</b>	min. 1000 mm (1 m/s) min. 1130 mm (1.6 m/s) min. 1360 mm (1.75 m/s)
<b>SP red.</b>	min. 450 mm (1 m/s)
<b>TH</b>	max. 40 m/min. 2900 mm (1 m/s) max. 75 m (>1 m/s)
<b>HST</b>	min. DH+450 mm / max. 11 m
<b>HST2</b>	min. 250 mm
<b>CH</b>	2100 – 2400 mm ( $\leq 1000$ kg) 2200 – 2500 mm (>1000 kg)
<b>DH</b>	2000 – 2300 mm ( $\leq 1000$ kg) 2000 – 2400 mm (>1000 kg)
<b>DW</b>	800 – 1000 mm ( $\leq 1000$ kg) 800 – 1800 mm (>1000 kg)

## Key

<b>SD</b>	shaft depth
<b>SW</b>	shaft width
<b>SH</b>	shaft head
<b>SP</b>	shaft pit
<b>red.</b>	reduced shaft head / shaft pit
<b>TH</b>	travel height
<b>HST(2)</b>	min. height between floors
<b>CH</b>	cabin height
<b>DH</b>	door height
<b>FFL</b>	finished floor level
<b>UFL</b>	unfinished floor level

**Note:** All shaft dimensions with standard tolerances. The values shown correspond to a generic installation under ideal circumstances. During the planning phase, all applicable regulations stipulated by relevant notified bodies and all applicable national regulations should be considered.

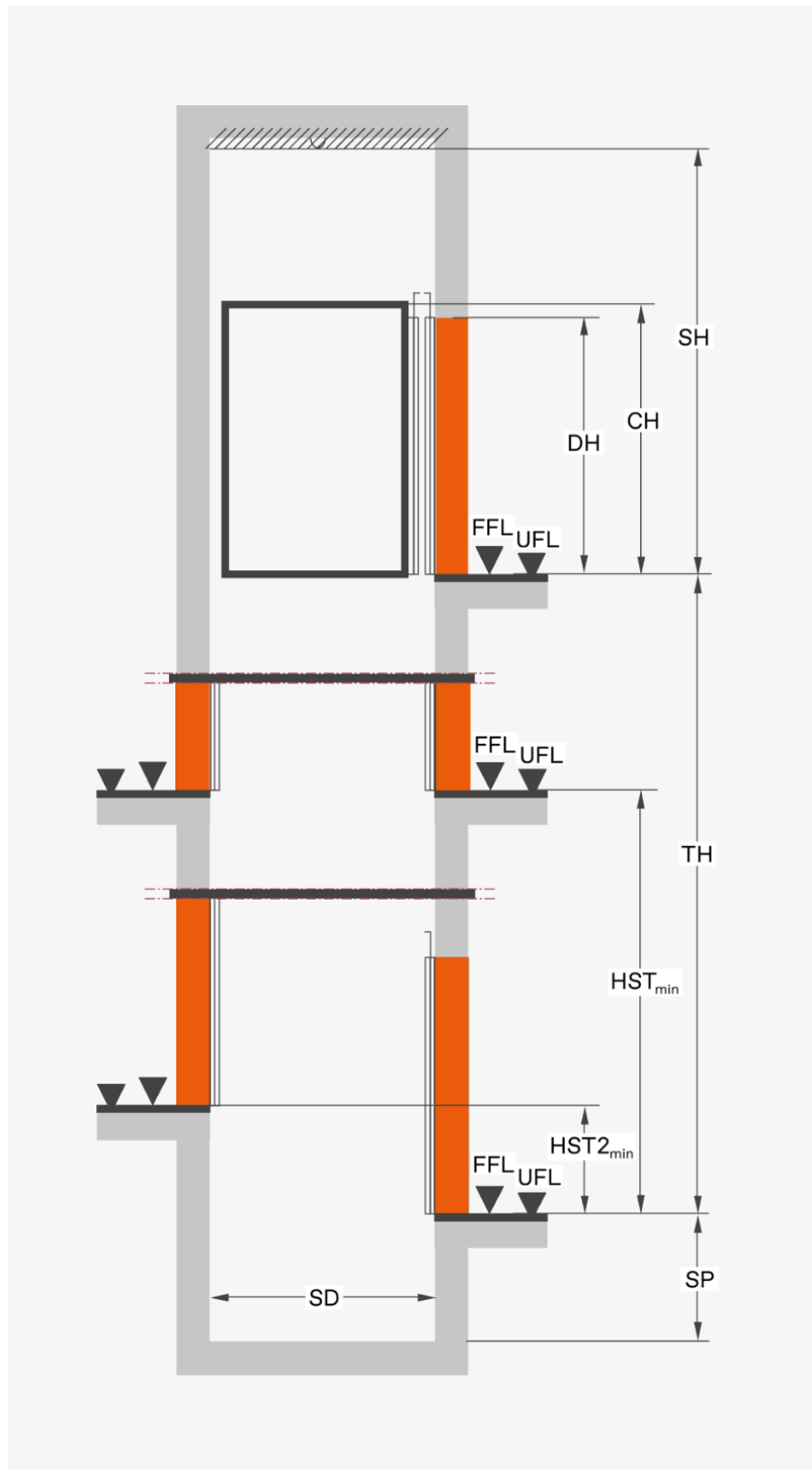



# Doors

## Key

<b>L2</b>	side-opening door with two door panels (800–1400 mm)
<b>C2</b>	central-opening door with two door panels (800–1400 mm)
<b>C4</b>	central-opening door with four door panels (1300–1800 mm)
<b>S</b>	single entrance
<b>D</b>	double entrance
<b>SD</b>	shaft depth
<b>CD</b>	cabin depth
<b>SW</b>	shaft width
<b>CW</b>	cabin width
<b>DW</b>	door width

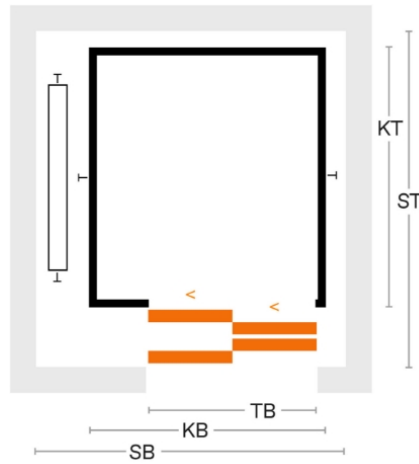

L2 / S

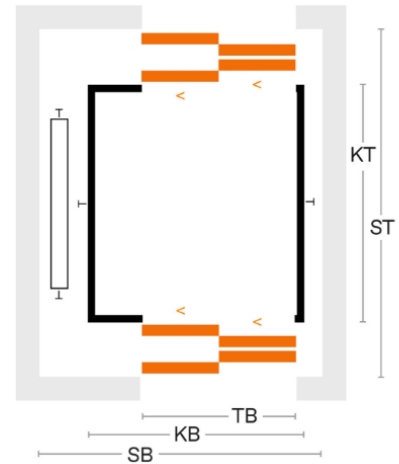

L2 / D

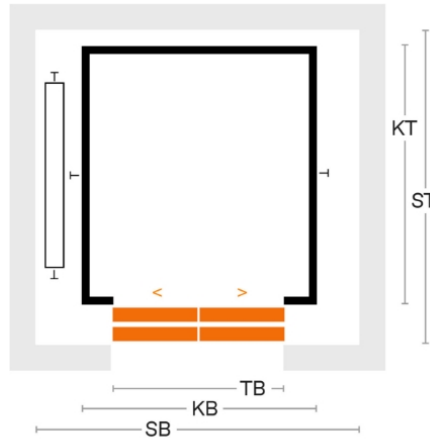

C2 / S

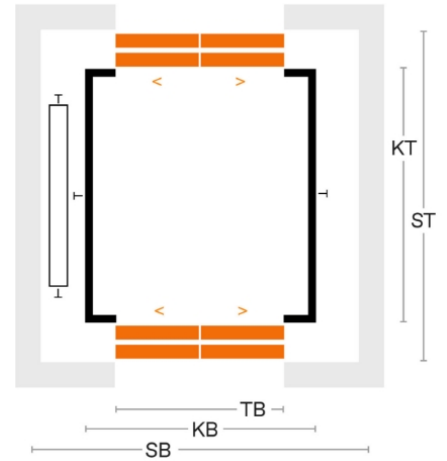

C2 / D

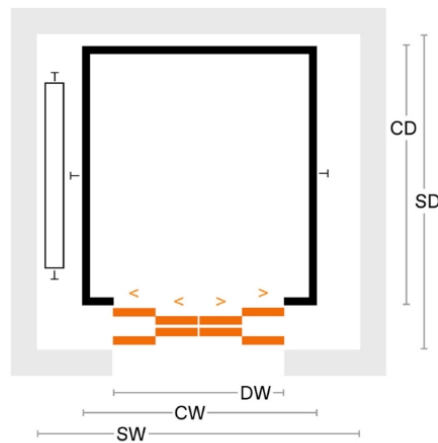

C4 / S

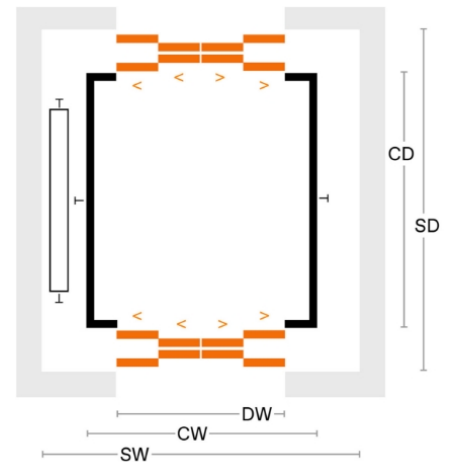

C4 / D

# Dimensions ≤1000 kg at 1.0 m/s

SYSTEM				CABIN		DOOR				SHAFT								
Rated load	Passengers	Speed	Travel height	Cabin width x depth	Cabin height	Entrance	Door type	Door width	Door height	Shaft width	SW full front	Shaft depth full front	SD door in recess	SD door partially in shaft	SD door in shaft	Shaft pit	Shaft head	
kg	N <sup>2</sup>	m/s	≤m	mm x mm	mm	S/D	L2/C2	mm		mm							mm	mm
<b>450</b>	<b>6</b>	<b>1.0</b>	<b>40</b>	<b>1000x1250</b>	<b>2100-2400</b>	<b>S/D</b>	<b>L2/C2</b>	<b>800-900</b>	<b>2000-2300</b>									
450	6	1.0	40	1000x1250	2200	S	L2	800	2000	1480	1500	1530	1530	1610	1655	1000	3380	
								900		1600	1600							
								800		1480	1500							
450	6	1.0	40	1000x1300	2200	D	L2	900	2000	1600	1600	1680	1680	1840	1930	1000	3380	
								800		1480	1500							
								900		1600	1600							
<b>450</b>	<b>6</b>	<b>1.0</b>	<b>40</b>	<b>1000x1300</b>	<b>2100-2400</b>	<b>S/D</b>	<b>L2/C2</b>	<b>800-900</b>	<b>2000-2300</b>									
450	6	1.0	40	1000x1300	2200	S	L2	800	2000	1480	1500	1580	1580	1660	1705	1000	3380	
								900		1600	1600							
								800		1480	1500							
450	6	1.0	40	1000x1300	2200	D	L2	900	2000	1600	1600	1730	1730	1890	1980	1000	3380	
								800		1480	1500							
								900		1600	1600							
<b>630</b>	<b>8</b>	<b>1.0</b>	<b>40</b>	<b>1100x1400</b>	<b>2100-2400</b>	<b>S/D</b>	<b>L2/C2</b>	<b>800-1000</b>	<b>2000-2300</b>									
630	8	1.0	40	1100x1400	2200	S	L2	800	2000	1600	-	-	1680	1760	1805	1000	3380	
								900		1600	1680							
								1000		1750	-							
						D	L2	800	1600	1600	1830	1830	1990	2080				
								900	1750	-	-	-	-					
								1000	1950	-	-	1645	1695	1735				
S	C2	900	1955	-	-	1760	1860	1940										
<b>825</b>	<b>10</b>	<b>1.0</b>	<b>40</b>	<b>1350x1400</b>	<b>2100-2400</b>	<b>S/D</b>	<b>L2/C2</b>	<b>800-1000</b>	<b>2000-2300</b>									
825	10	1.0	40	1350x1400	2200	S	L2	900	2000	1850	1850	1680	1680	1760	1805	1000	3380	
								1000			-	-						
						D	L2	900	1850	1830	1830	1990	2080					
								1000	2150	-	-	1645	1695	1735				
S	C2	1000	2155	-	-	1760	1860	1940										
<b>1000</b>	<b>13</b>	<b>1.0</b>	<b>40</b>	<b>1100x2100</b>	<b>2100-2400</b>	<b>S/D</b>	<b>L2/C2</b>	<b>800-1000</b>	<b>2000-2300</b>									
1000	13	1.0	40	1100x2100	2200	S	L2	800	2000	1600	-	-	2380	2460	2505	1000	3380	
								900		1600	2380							
								1000		1750	-							
						D	L2	800	1600	1600	2530	2530	2690	2780				
								900	1750	-	-	-	-					
								1000	1950	-	-	2345	2395	2435				
S	C2	900	1955	-	-	2460	2560	2640										
<b>1000</b>	<b>13</b>	<b>1.0</b>	<b>40</b>	<b>1600x1400</b>	<b>2100-2400</b>	<b>S/D</b>	<b>L2/C2</b>	<b>800-1000</b>	<b>2000-2300</b>									
1000	13	1.0	40	1600x1400	2200	S	L2	900	2000	2100	-	-	1680	1760	1805	1000	3380	
								1000										
						D	L2	900	2220	-	-	1830	1990	2080				
								1000	2220	1645	1695	1735						
S	C2	1000	2220	-	-	1760	1860	1940										
<b>1000</b>	<b>13</b>	<b>1.0</b>	<b>40</b>	<b>1400x1600</b>	<b>2100-2400</b>	<b>S/D</b>	<b>L2/C2</b>	<b>800-1000</b>	<b>2000-2300</b>									
1000	13	1.0	40	1400x1600	2200	S	L2	900	2000	1900	-	-	1880	1960	2005	1000	3380	
								1000										
								900										
						D	L2	900	2150	-	-	2030	2190	2280				
1000	2155	1845	1895	1935														
S	C2	1000	2155	-	-	1960	2060	2140										

**Extra-reduced shaft head and pit:** see dedicated page. **Flexible cabin dimensions:** Optionally, the standard cabin dimensions can be adjusted in 10 mm steps (≤ 630 kg) or 100 mm steps (>630 kg). **Key:** S: Single entrance, D: Double entrance, L2: Side-opening door with 2 panels, SW: Shaft width, SD: Shaft depth. **Note:** All shaft dimensions with standard tolerances. Dimensions in this table are valid for CH=2200 mm and DH=2000 mm with standard shaft head and pit.

# Dimensions >1000 kg at 1.0 m/s

SYSTEM				CABIN		DOOR				SHAFT								
Rated load	Passengers	Speed	Travel height	Cabin width x depth	Cabin height	Entrance	Door type	Door width	Door height	Shaft width	SW full front	Shaft depth full front	SD door in recess	SD door partially in shaft	SD door in shaft	Shaft pit	Shaft head	
kg	Nº	m/s	≤m	mm x mm	mm	S/D	L2/C2/C4	mm		mm							mm	mm
<b>1150</b>	<b>15</b>	<b>1</b>	<b>40</b>	<b>1200x2100</b>	<b>2200-2500</b>	<b>S/D</b>	<b>L2/C2</b>	<b>800-1100</b>	<b>2000-2400</b>									
1150	15	1	40	1200x2100	2200	S	L2	1100	2000	1915	1930	2380 2530	2380 2530	2460 2690	2505 2780	1000	3410	
						D												
						S	C2	1000										
						D												
<b>1275</b>	<b>17</b>	<b>1</b>	<b>40</b>	<b>1200x2300</b>	<b>2200-2500</b>	<b>S/D</b>	<b>L2/C2</b>	<b>800-1100</b>	<b>2000-2400</b>									
1275	17	1	40	1200x2300	2200	S	L2	1100	2000	1915	1930	2580 2730	2580 2730	2660 2890	2705 2980	1000	3410	
						D												
						S	C2	1000										
						D												
<b>1275</b>	<b>17</b>	<b>1</b>	<b>40</b>	<b>2000x1400</b>	<b>2200-2500</b>	<b>S/D</b>	<b>L2/C2/C4</b>	<b>1100-1700</b>	<b>2000-2400</b>									
1275	17	1	40	2000x1400	2200	S	L2	1300	2000	2615			1680 1830	1760 1990	1805 2080	1000	3680	
						D												
						S	C2	1400										
						D												
S	C4	1700																
D																		
<b>1350</b>	<b>18</b>	<b>1</b>	<b>40</b>	<b>2000x1500</b>	<b>2200-2500</b>	<b>S/D</b>	<b>L2/C2/C4</b>	<b>1100-1700</b>	<b>2000-2400</b>									
1350	18	1	40	2000x1500	2200	S	L2	1400	2000	2615			1780 1930	1860 2090	1905 2180	1000	3680	
						D												
						S	C2	1700										
						D												
S	C4	1700																
D																		
<b>1600</b>	<b>21</b>	<b>1</b>	<b>40</b>	<b>1400x2400</b>	<b>2200-2500</b>	<b>S/D</b>	<b>L2/C2/C4</b>	<b>800-1300</b>	<b>2000-2400</b>									
1600	21	1	40	1400x2400	2200	S	L2	1300	2000	2215	2230	2680 2830	2680 2830	2760 2990	2805 3080	1000	3410	
						D												
						S	C2	1100										
						D												
S	C4	1300																
D																		
<b>1600</b>	<b>21</b>	<b>1</b>	<b>40</b>	<b>2100x1600</b>	<b>2200-2500</b>	<b>S/D</b>	<b>L2/C2/C4</b>	<b>1200-1800</b>	<b>2000-2400</b>									
1600	21	1	40	2100x1600	2200	S	L2	1400	2000	2715			1880 2030	1960 2190	2005 2280	1000	3680	
						D												
						S	C2	1800										
						D												
S	C4	1800																
D																		
<b>1600</b>	<b>21</b>	<b>1</b>	<b>40</b>	<b>1600x2100</b>	<b>2200-2500</b>	<b>S/D</b>	<b>L2/C2/C4</b>	<b>800-1400</b>	<b>2000-2400</b>									
1600	21	1	40	1600x2100	2200	S	L2	1400	2000	2365	2380	2380 2530	2380 2530	2460 2690	2505 2780	1000	3410	
						D												
						S	C2	1200										
						D												
S	C4	1400																
D																		

**Flexible cabin dimensions:** Optionally, the standard cabin dimensions can be adjusted in 100 mm steps. **Key:** S: Single entrance, D: Double entrance, L2: Side-opening door with 2 panels, C2: Central-opening door with 2 panels, C4: Central-opening door with 4 panels, SW: Shaft width, SD: Shaft depth. **Note:** All shaft dimensions with standard tolerances. Dimensions in this table are valid for CH=2200 mm and DH=2000 mm with standard shaft head and shaft pit. Extra-reduced shaft head is not available for loads >1000 kg.

# Dimensions at 1.6 and 1.75 m/s

SYSTEM				CABIN		DOOR				SHAFT							
Rated load	Passengers	Speed	Travel height	Cabin width x depth	Cabin height	Entrance	Door type	Door width	Door height	Shaft width	SW full front	Shaft depth full front	SD door in recess	SD door partially in shaft	SD door in shaft	Shaft pit	Shaft head
630	8	1.6/1.75	75	1100x1400	2100-2400	S/D	L2/C2	800-1000	2000-2300								
630	8	1.6	75	1100x1400	2200	S	L2	900	2000	1600	1600	1685	1685	1765	1810	1130	3615
								1000		1750	-	-					
		900						1600		1600	1685						
		1000						1750		-	-						
825	10	1.6/1.75	75	1350x1400	2100-2400	S/D	L2/C2	800-1000	2000-2300								
825	10	1.6	75	1350x1400	2200	S	L2	900	2000	1850	-	1685	1685	1765	1810	1130	3615
								1000			-	-					
		900						1850			1685						
		1000						-			-						
1000	13	1.6/1.75	75	1100x2100	2100-2400	S/D	L2/C2	800-1000	2000-2300								
1000	13	1.6	75	1100x2100	2200	S	L2	800	2000	1600	-	-	2385	2465	2510	1130	3615
								900		1750	-	-					
								1000		1600	-	-					
		1.75						800		1600	1600	2385				1360	3735
								900		-	-						
								1000		-	-						
1150	15	1.6/1.75	75	1200x2100	2200-2500	S/D	L2/C2	800-1100	2000-2400								
1150	15	1.6	75	1200x2100	2200	S	L2	900	2000	1745	1750	2380	2380	2460	2505	1250	3590
							C2	1000		2160	-	-	2345	2395	2435		
		1.75					L2	900		1745	1750	2380	2380	2460	2505	1350	3650
							C2	1000		2160	-	-	2345	2395	2435		
1275	17	1.6/1.75	75	1200x2300	2200-2500	S/D	L2/C2	800-1100	2000-2400								
1275	17	1.6	75	1200x2300	2200	S	L2	1100	2000	1915	1930	2580	2580	2660	2705	1250	3590
							C2	1000		2160	-	-	2545	2595	2635		
		1.75					L2	1100		1915	1930	2580	2580	2660	2705	1350	3650
							C2	1000		2160	-	-	2545	2596	2635		
1275	17	1.6/1.75	75	2000x1400	2200-2500	S/D	L2/C2/C4	1100-1700	2000-2400								
1275	17	1.6	75	2000x1400	2200	S	L2	1300	2000	2615	-	-	1680	1760	1805	1250	3860
							C2	1400		2960	-	-	1645	1695	1735		
							L2	1300		2615	-	-	1680	1760	1805		
		1.75					C2	1400		2960	-	-	1645	1695	1735	1350	3920
							L2	1300		2615	-	-	1680	1760	1805		
1350	18	1.6/1.75	75	2000x1500	2200-2500	S/D	L2/C2/C4	1100-1700	2000-2400								
1350	18	1.6	75	2000x1500	2200	S	L2	1300	2000	2615	-	-	1780	1860	1905	1250	3860
							C2	1400		2960	-	-	1745	1795	1835		
							L2	1300		2615	-	-	1780	1860	1905		
		1.75					C2	1400		2960	-	-	1745	1795	1835	1350	3920
							L2	1300		2615	-	-	1780	1860	1905		
1600	21	1.6/1.75	75	1400x2400	2200-2500	S/D	L2/C2/C4	800-1300	2000-2400								
1600	21	1.6	75	1400x2400	2200	S	L2	1300	2000	2215	2230	2680	2680	2760	2805	1250	3590
							C2	1100		2360	-	-	2645	2695	2735		
							L2	1300		2215	2230	2680	2680	2760	2805		
		1.75					C2	1100		2360	-	-	2645	2695	2735	1350	3650
							L2	1300		2215	2230	2680	2680	2760	2805		
1600	21	1.6/1.75	75	2100x1600	2200-2500	S/D	L2/C2/C4	1200-1800	2000-2400								
1600	21	1.6	75	2100x1600	2200	S	L2	1300	2000	2715	-	-	1880	1960	2005	1250	3860
							C2	1400		2960	-	-	1845	1895	1935		
							L2	1300		2715	-	-	1880	1960	2005		
		1.75					C2	1400		2960	-	-	1845	1895	1935	1350	3920
							L2	1300		2715	-	-	1880	1960	2005		
1600	21	1.6/1.75	75	1600x2100	2200-2500	S/D	L2/C2/C4	800-1400	2000-2400								
1600	21	1.6	75	1600x2100	2200	S	L2	1300	2000	2215	2230	2380	2380	2460	2505	1250	3590
							C2	1200		2560	-	-	2345	2395	2435		
							L2	1300		2215	2230	2380	2380	2460	2505		
		1.75					C2	1200		2560	-	-	2345	2395	2435	1350	3650
							L2	1300		2215	2230	2380	2380	2460	2505		

**Flexible cabin dimensions:** Optionally, the standard cabin dimensions can be adjusted in 10 mm steps (≤630 kg) or 100 mm steps (>630 kg). **Key:** S: Single entrance, D: Double entrance, L2: Side-opening door with 2 panels, C2: Central-opening door with 2 panels, C4: Central-opening door with 4 panels, SW: Shaft width, SD: Shaft depth. **Note:** All shaft dimensions with standard tolerances. Dimensions in this table are valid for CH=2200 mm and DH=2000 mm with standard shaft head and shaft pit. Extra-reduced shaft head is not available for speeds >1 m/s.

# EOX as a firefighter elevator

Buildings above a certain height require a dedicated lift that is specifically equipped to be used by firefighters during a building fire or other emergency. EOX can be configured to meet the demands of the EN 81-72 firefighter elevator standard.

## Special features of the EOX firefighter lift

To remain operational under smoky and damp conditions, the EOX firefighter lift fulfils IPX3 protection requirements for electrical components in the shaft and the cabin.

The cabin ceiling includes a 700×500 mm emergency trapdoor with an integrated telescopic ladder, allowing firefighters to exit and enter through the elevator shaft.

The EOX firefighter lift's IL Variable cabin operating panel and Series 50 landing operating panels come equipped with vandal-resistant VB push-buttons. For access control and intercom between the cabin and the landing, a special firefighter access box is supplied.

## Cabin design

Stainless steel and stainless steel linen cabins from Design lines C and B. All mirror, handrail and flooring options are available. Ceiling options offered are special firefighter lift versions of the Steel Grille and Steel Lightbox ceilings.

## Technical scope

630, 825 or 1.000 kg load, speed of up to 1.75 m/s and up to 75 m travel height and 20 stops. Single or double entrance, L2 or C2 doors. Reduced shaft head or pit are not available.

**Cabin visualisation:** 1.000 kg, 1100×2100 mm, Design line B with stainless steel linen walls, Steel Grille firefighter ceiling with trapdoor and ladder behind rear ceiling panel. Landing operating panel LOP 53 with VB buttons, landing indicator LIP 50.



**Please note:** The EN 81-72 standard defines the basic requirements and functionality of firefighter lifts. Country-specific or even regional laws and additional regulations may apply. Your TK Elevator contact will gladly advise you and assist in engineering the right EOX firefighter lift for you.

# EOX with extra-reduced shaft head and reduced pit

When building in densely populated urban areas, every millimetre and every second counts. With the option of the extra-reduced shaft head and reduced shaft pit, EOX saves on vertical space and construction time. Shortening the shaft head to a room-height level means that architects and planners no longer have to design the top floor and roof around a higher elevator shaft, and contractors don't get caught up with ceiling penetrations and superstructures.



In this visualisation, the buildings on the left side of the street feature EOX elevators with a standard shaft head requiring roof superstructures. Buildings on the right feature EOX elevators with extra-reduced shaft head resulting in an obstacle-free roof for terraces, PV panels, etc.



Explore an interactive experience of this content in the digital version of the product brochure. Scan the QR code with your phone or visit [brochure.tkelevator.com/en-EA/eox](https://brochure.tkelevator.com/en-EA/eox)



## Starting from 2.500 mm

Measured from the finished floor of the building top level, the shaft head for your EOX elevator can be reduced from the standard  $\geq 3.280$  mm to as low as 2.500 mm.



## No complex roof superstructures

The ability to finish the elevator shaft within room height puts an end to “hood”-like roof superstructures, and the top ceiling can be poured as one continuous floor slab.



## Architectural design freedom

Architects are free from having to constantly consider an elevator shaft that “sticks out” of the building. In areas with strict building height limits, design-critical space is gained.



## Space for PVs, terraces etc.

With the elevator staying below the final floor slab, the building roof becomes an obstacle-free surface that can be used for photovoltaic systems, apartment terraces etc.



## Maintenance from the cabin

When the extra-reduced shaft head option is chosen, the EOX cabin comes with a ceiling-integrated foldable working platform, enabling the service technician to perform maintenance safely from the cabin without having to board the cabin roof.



## Reduced shaft pit

For the shaft pit, the optional reduction results in a minimum height as low as 450 mm instead of the standard 1.000 mm. Combination of reduced pit option with extra-reduced shaft head is possible, although restrictions may apply.



## Available from 450 to 1.000 kg

Both reduction options are available for rated loads from 450 to 1.000 kg. The reduced pit option can be applied to all cabin sizes (incl. flexible dimensions). The extra-reduced shaft head requires standard cabin dimensions.



## Certified and quiet

The options for the extra-reduced shaft head and reduced shaft pit are type-tested and conform with EN 81-20/50 and EN 81-21. Noise performance data proves that EOX is a quiet lift system. The entry value (at 630 kg, 1 m/s) of just 24 db(A) in adjacent rooms means that an EOX from next door is quieter than a whisper.



### Further information on the application of extra-reduced shaft head and reduced pit

The extra-reduced shaft head and reduced pit options are available exclusively for EOX elevators with max. 1 m/s. Reduced shaft pit is applicable to all cabin sizes, including flexible cabin sizes. Extra-reduced shaft head is applicable only to standard dimension cabins: 450 kg (1000×1250 and 1000×1300 mm), 630 kg (1100×1400 mm), 825 kg (1350×1400 mm) and 1000 kg (1100×2100 mm). Cabins are exclusively available with Steel Lightbox and Steel Grille ceilings. Minimum achievable shaft head is dependent on the chosen rated load, cabin height, door height and door type as well as door model. For example, the lowest extra-reduced shaft head of 2500 mm is achieved at 630 kg with 2100 mm cabin height and a low-buildup door model of 2000 mm height. Combination of extra-reduced shaft head and reduced pit is possible, although restrictions may apply depending on the specific configuration of your EOX elevator. Your TK Elevator contact will gladly guide you through the planning process for your project.

# Smart and easy maintenance

TK Elevator's cloud-based smart maintenance – for which EOX comes “plug and play”-ready – provides intelligent data analytics packaged to fit your service needs. It results in enhanced service quality, less paperwork, real-time equipment transparency and increased peace of mind.



Through its smart sensors and connected components EOX can collect real-time data to calculate the remaining lifetime of each of the elevator's key components, determining which parts will require maintenance, a readjustment, a repair or a replacement – and when. Door movements, speed, number of trips and power-ups, car calls – all this and more is aggregated and sent to the cloud where algorithms analyse it for patterns and determine the “health” of your elevator. This data-driven approach has the power to cut elevator downtime by up to 50%.

And the best thing about it: It's at the fingertips of all parties involved – for the owner or a building manager through the included TK Elevator Customer Portal, as well as the service technician in charge of the elevator. Independent of the type of maintenance contract with TK Elevator, every EOX owner benefits from advanced troubleshooting as well as notifications and critical alerts. Performance data and diagnostics delivered to our technicians in real time indicate where intervention is required. The pre-defined notification contacts are also informed about any incidents. What does that mean for you? Maximum transparency, fewer unscheduled visits, quicker clearing of breakdowns or malfunctions and increased uptime for passengers and tenants.

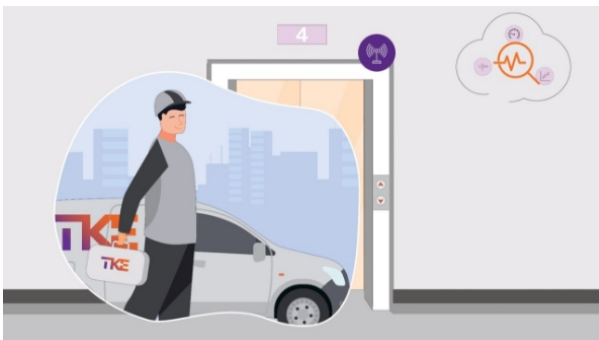
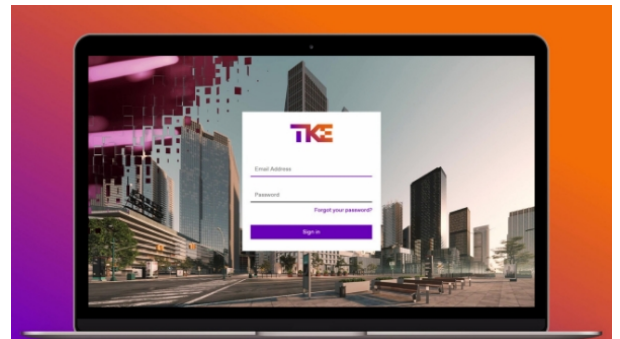

TK Elevator was the first to introduce the elevator industry to a fundamental shift from reactive to proactive maintenance. With EOX, this is now a standard for even the most basic everyday elevators. Our first-mover advantage combined with cutting-edge cloud technology, IoT connectivity and Big Data analysis gets you more transparency, prolonged lifetime for your units, and enhanced safety and reliability for your passengers.



# About TK Elevator

We are elevator people. Striving to move the world. Known for a passion for technology with service at the heart of our business.



Over the past decades, TK Elevator has established itself as one of the world's leading elevator companies and became independent after its sale by thyssenkrupp AG in August 2020. To our customers in over 100 countries we provide an extensive service network that guarantees close proximity, with more than 1.000 locations and over 50.000 employees. TK Elevator's most important business line is our multi-brand service for mobility solutions represented by over 25.000 service technicians.

Our new installation product portfolio ranges from commodity elevators for residential and commercial buildings to cutting-edge, highly customised solutions for state-of-the-art skyscrapers. What's more, it also consists of escalators and moving walks, passenger boarding bridges, stair and platform lifts. Integrated cloud-based service solutions are gaining in importance. These digital offerings mean there are no longer any limits to urban mobility.

**TK Elevator. Move beyond.**

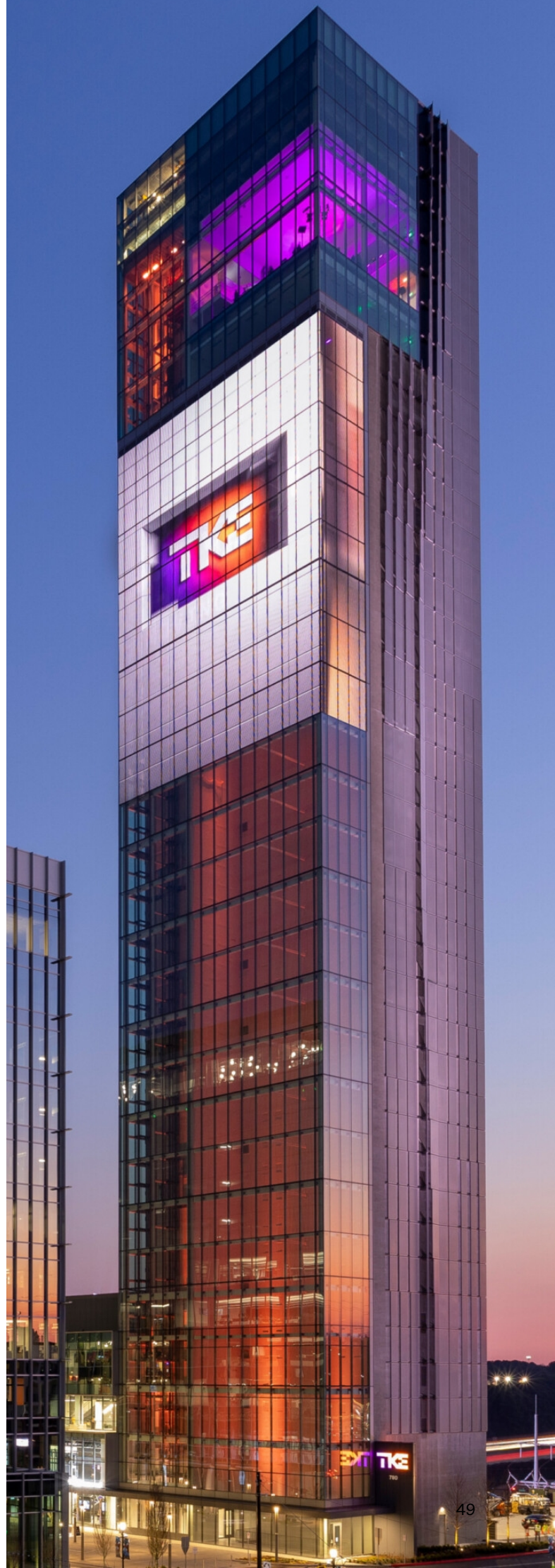

# Advancing mobility and eco-transparency

The commitment to sustainable mobility is an integral part of TK Elevator. It determines how we work – starting with product design, and extending to improved transparency and greater commitment along the entire value chain, including in production, installation, operations and maintenance.

Being one of the world's leading elevator companies, we are dedicated to driving innovation and continuous improvement, all in close partnership with our stakeholders.

**Learn more about TK Elevator's ESG efforts**



[www.tkelevator.com/global-en/sustainability](http://www.tkelevator.com/global-en/sustainability)

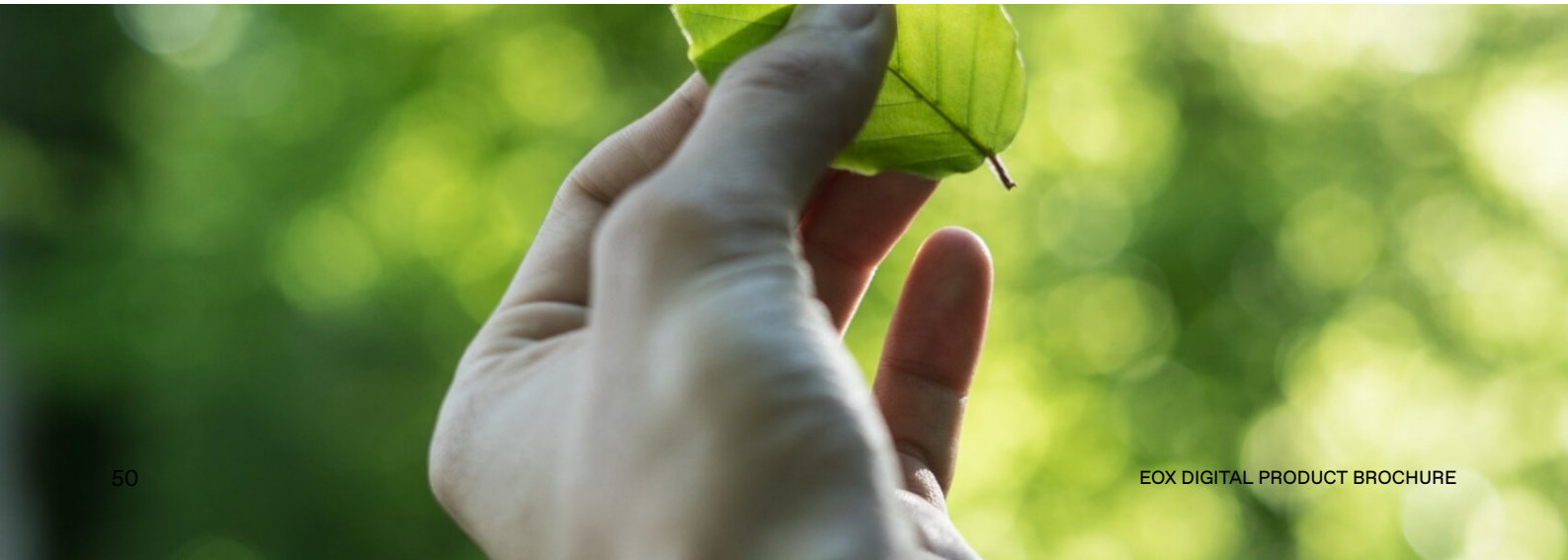

# Our efforts are recognised by...



## CDP A-list

TK Elevator is recognised in the acclaimed A-list published by the global non-profit organisation CDP.



## EcoVadis

We were awarded the EcoVadis gold medal, with TK Elevator now ranking among the top 2% of all companies currently assessed by the sustainability rating agency.



## Sustainalytics

TK Elevator tops the Sustainalytics global ESG risk rating in the machinery industry category and has achieved the best result among over 500 machinery companies.



## Supplier Engagement Leader

We were recognised by CDP as a “Supplier Engagement Leader” for taking action to measure and reduce environmental risks within our supply chain.



## UN Global Compact

TK Elevator is a signatory of the UN Global Compact.



## Global Elevator Safety Forum

TK Elevator is a co-founder of the Global Elevator Safety Forum to pursue a safe industry without accidents.



## Member of RE100

We joined the worldwide RE100 (Renewable Electricity) initiative and committed to only use renewable electricity across our global operations by 2030.



## The Science Based Targets

The Science Based Targets initiative approved TK Elevator’s emission reduction targets as being consistent with the levels required to meet the goals of the Paris Climate Agreement.

## We put our ESG commitments in writing – with full transparency

TK Elevator’s sustainability report provides an overview of our progress as well as the clear commitments we have made with regard to environmental protection, social responsibility, and governance (ESG). We embrace the challenges of sustainability and are committed to leading the way in creating environmentally friendly mobility solutions. Find the TK Elevator Sustainability Report on our website.





EOX.TKELEVATOR.COM

TK Elevator Europe Africa GmbH  
E-Plus-Strasse 1  
40472 Düsseldorf  
Germany  
info@tkelevator.com

EOX digital product brochure en-EA v18/12/2024 Ext1C  
The details quoted in this brochure can only be viewed as binding when confirmed expressly in writing. Reproduction and storage only with authorization of TK Elevator. Colours, options and specifications are subject to change. Provision of all digital (software) services is dependent on an active maintenance contract with TK Elevator. All cabin design and multimedia display options shown in this brochure are for illustrative purposes only. Samples shown may vary from the original in colour and material. Patterned samples are not to scale. Your TK Elevator contact will gladly provide you with real material samples.